

# PATENT ABSTRACTS OF JAPAN

(11)Publication number : 10-207624

(43)Date of publication of application : 07.08.1998

(51)Int.Cl.

G06F 3/033  
A63F 9/22

(21)Application number : 09-007834

(71)Applicant : TAITO CORP

(22)Date of filing : 20.01.1997

(72)Inventor : AGAWA HAJIME

## (54) JOY STICK FOR GAME

(57)Abstract:

**PROBLEM TO BE SOLVED:** To move a character of a game in three dimensions and to change the direction of the character through operation by moving the character in a three-dimensional space and also rotating it in three axial directions by operating respective sensors and variable resistors.

**SOLUTION:** The three-dimensional space displayed on a display device has X, Y, and Z axes and rotary vector coordinate  $X_r$ ,  $Y_r$ , and  $Z_r$  axes and the character is displayed. Variation in the values of respective variable resistors for the X, Y, and Z axes moves the character in the XYZ three-dimensional space. Variation in the values of an X-axial variable resistor 15, a Y-axial variable resistor 16, and a Z-axial variable resistor 17 rotate the character on the rotary vector coordinate  $X_r$ ,  $Y_r$ , and  $Z_r$  axes to change the direction. When the sensors and variable resistors are varied in value continuously, the character rotates while moving and moves while rotating in the three-dimensional space to change the direction.

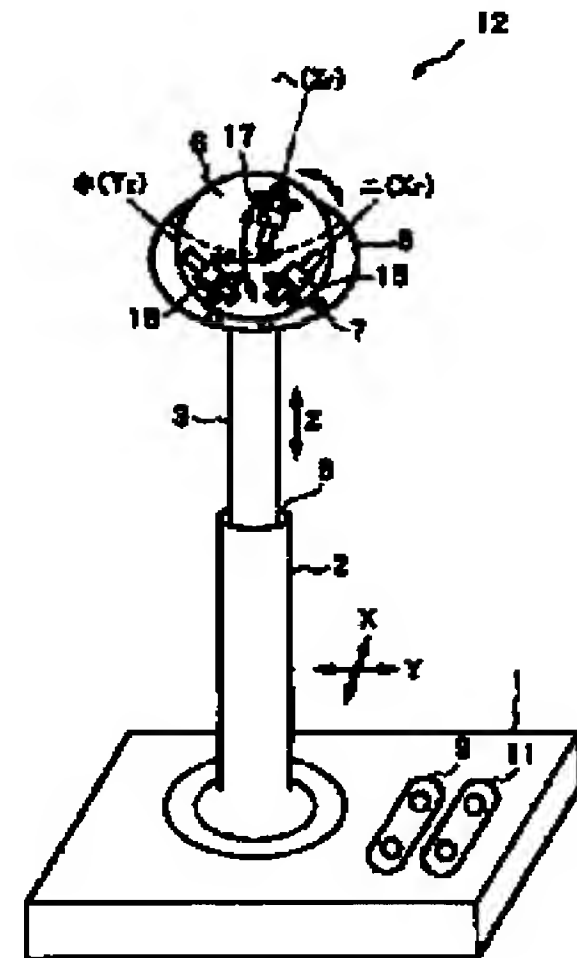

**\* NOTICES \***

JPO and INPIT are not responsible for any damages caused by the use of this translation.

- 1.This document has been translated by computer. So the translation may not reflect the original precisely.
- 2.\*\*\* shows the word which can not be translated.
- 3.In the drawings, any words are not translated.

---

**CLAIMS**

---

[Claim(s)]

[Claim 1]A character signal generated by a game generating part and position data by which it was generated in a joystick are added and processed by a display control part, In a joystick for games to which it displays on three-dimensional space on a display, a joystick is operated, and a character is moved in three-dimensional space, The first operating rod that provided said joystick in a box-like holding part and this holding part rotatable, Between the second operating rod slidably provided in this first operating rod, an attaching part provided at a tip of this second operating rod, a bulb provided in this attaching part rotatable, and said holding part and the first operating rod, The first sensor and second sensor that were formed so that the axis of rotation might cross mutually, The third sensor formed between said first operating rod and the second operating rod, It has the first volume, second volume, and third volume that were provided so that the axis of rotation might cross mutually between said attaching part and a bulb, \*\*\* said attaching part, and rotate the first operating rod to a holding part, slide the second operating rod to the first operating rod, and also a bulb is rotated to said attaching part, A joystick for games operating said sensor and volume, moving a character in three-dimensional space, and rotating 3 shaft orientations with \*\*.

---

[Translation done.]

\* NOTICES \*

JPO and INPIT are not responsible for any damages caused by the use of this translation.

1.This document has been translated by computer. So the translation may not reflect the original precisely.

2.\*\*\* shows the word which can not be translated.

3.In the drawings, any words are not translated.

---

## DETAILED DESCRIPTION

---

[Detailed Description of the Invention]

[0001]

[Field of the Invention]Especially this invention is made into the 6-dimensional joystick which added rotational movement to three-dimensional movement about the joystick for games in Seki.

[0002]

[Description of the Prior Art]The conventional joy stick can operate only in the direction of two dimensions.

Also in the game using three-dimensional space which has spread widely now, since a character moved background scenes and play space only in the direction of two dimensions even if they are three dimensions, dissatisfaction remained in the motion.

Since it cannot do even if it gives and cooks change of direction in a character by operation, the motion is simple.

[0003]

[Problem to be solved by the invention]Since a character moved background scenes and play space by the game using conventional three-dimensional space only in the direction of two dimensions even if they are three dimensions, force was missing. An object of this invention is to provide the joystick which gives change of direction to a character and can do things by operation while moving the character in a game in the direction of a three dimension.

[0004]

[Means for solving problem]This invention adds and processes the character signal generated by the game generating part, and the position data by which it was generated in the joystick by a display control part, and displays it on three-dimensional space on a display, and the joystick for games to which a joystick is operated and a character is moved in three-dimensional space is improved. The first operating rod that provided the joystick in a box-like holding part and this holding part rotatable, the second operating rod slidably provided in this first operating rod, the attaching part provided at the tip of this second operating rod, and the bulb provided in this attaching part rotatable are provided. The first sensor and second sensor that were formed between a holding part and the first operating rod so that the axis of rotation might cross mutually, It has the first volume, second volume, and third volume that were provided so that the axis of rotation might cross mutually between the third sensor formed between said first operating rod and the second operating rod, and said attaching part and a bulb. \*\*\* an attaching part, and rotate the first operating rod to a holding part, and the second operating rod is slid to the first operating rod, A bulb is rotated to said attaching part, said each sensor and volume are operated, said character is moved in three-dimensional space, and 3 shaft orientations are rotated with \*\*.

[0005]

[Mode for carrying out the invention]

Below embodiment 1. explains this invention according to Drawings. Drawing 4 indicates the display example of the display device 25 to be a block circuit diagram of a game machine or a computer, and explanation top rectangular coordinates are also repeatedly shown in the display devices 25, such as CRT and a liquid crystal. However, generally rectangular coordinates are not displayed in a actual game screen.

[0006]The picture generation circuit 80 which is a game generating part generates the image of game software, and a video signal is sent to the picture display control circuit 90 of a display control part. Generate the joystick 1 and the position data of an operational input system The X-axis volume 10 of the first sensor for movement, Y-axis Ruhm 20 of the second sensor, and the Z-axis volume 30 of the third sensor, And it has the X-axis rotating volume 15 of the first volume

for rotation, the Y-axis rotating volume 16 of the second volume, and the Z-axis rotating volume 17 of the third volume.

[0007]The signal from such sensors and volumes is sent to the picture display control circuit 90, is added to the image data of the image of game software, and is sent to the display device 25 of a display.

[0008]Three-dimensional space displayed on the display device 25 has a XYZ axis and a rotation vector coordinates  $X_r Y_r Z_r$  axis, and the character 26 is displayed. In the value change of the X-axis volume 10, Y-axis volume 20, and the Z-axis volume 30, in three-dimensional space, the character 26 performs movement in XYZ three-dimensional space.

[0009]The character 26 rotates focusing on a rotation vector coordinates  $X_r Y_r Z_r$  axis, and the value change of the X-axis rotating volume 15, the Y-axis rotating volume 16, and the Z-axis rotating volume 17 changes direction in three-dimensional space.

[0010]If the value of such sensors and volumes is changed continuously, in three-dimensional space, it will move rotating [ rotate, while the character 26 moves, and ], and direction will be changed. Next, such sensors and volumes explain the composition included in the joystick 12 by drawing 1, and 2 and 3.

[0011]Drawing 1 expresses the overview of the joystick 12 of an application concerned typically. First, the base 2 which is the first operating rod of the joystick 12 is formed in the stand 1 which is a box-like holding part rotatable, the base 2 is a cylinder pillar which has the hollow hole 8, and the chief editor 3 who is the second cylindrical and a little thin operating rod inserts it in the hollow hole 8 of the base 2 slidably, and it is provided in it.

[0012]Attached, the spherical shell 5 which is an attaching part of hollow of size restored to a help's grip at the chief editor's 3 point cut the spherical shell 5 to near the upper half, and it has withered in \*\*. The sphere 6 which is a bulb of a byway a little is held in hollow of the spherical shell 5, enabling free rotation, and the notch range of the spherical shell 5 is carried out to such an extent that the sphere 6 does not drop out of the spherical shell 5.

[0013]The spherical shell 5 has the thickness of a processible grade, among those it distributes in a direction, many hemispherical stomata are formed in it, the ball bearing 7 is inserted in these stomata, respectively, and the sphere 6 is held within the spherical shell 5 via the ball bearing 7, enabling free rotation.

[0014]In drawing 3, the indirect ball 13 is formed in a lower end part of the base 2, and the X-axis volume 10 of the first sensor and Y-axis volume 20 of the second sensor are stationed at stand 1 inside. The X-axis volume 10 and the Y-axis volume 20 are rotation sensors, it has axis-of-rotation I and RO, and these axes-of-rotation I and RO cross mutually.

[0015]Where the basis group 2 is assembled on the stand 1, if the X-axis volume 10 and the Y-axis volume 20 are contacted, and the indirect ball 13 receives stand 1 and rotates the base 2, the indirect ball 13 will also rotate, the X-axis volume 10 and the Y-axis volume 20 will rotate by the reaction, and an output value of these rotation sensor will change.

[0016]If the Z-axis volume 30 of the third sensor is arranged and the chief editor 3 is slid on a sliding direction to the base 2 as shown in drawing 2, Z-axis volume 30 will rotate between the base 2 and the chief editor 3, and the output value will change to it. Change of the output of the X-axis volume 10, the Y-axis volume 20, and the Z-axis volume 30 moves the character 26 in the XYZ direction in three-dimensional space on the display device 25 of drawing 4, respectively.

[0017]Next, in drawing 1, the X-axis rotating volume 15 of the first volume, the Y-axis rotating volume 16 of the second volume, and the Z-axis rotating volume 17 of the third volume are arranged so that the axis of rotation may cross mutually between the spherical shell 5 of an attaching part, and the bulb 6. These X-axis rotating volume 15, the Y-axis rotating volume 16, and the Z-axis rotating volume 17 are rotation sensors, it has axis-of-rotation NI, HO, and HE, and these axes-of-rotation NI, HO, and HE cross mutually in three dimensions.

[0018]If the bulb 6 contacts the X-axis rotating volume 15, the Y-axis rotating volume 16, and the Z-axis rotating volume 17 and the bulb 6 rotates within the spherical shell 5, these X-axis rotating volume 15, the Y-axis rotating volume 16, and the Z-axis rotating volume 17 will rotate focusing on each axis.

[0019]Rotation of the bulb 6 will change the output of the X-axis rotating volume 15, the Y-axis rotating volume 16, and the Z-axis rotating volume 17. The change of the output value of the X-axis rotating volume 15, the Y-axis rotating volume 16, and the Z-axis rotating volume 17 can swerve focusing on a rotation vector coordinates  $X_r Y_r Z_r$  axis, and rotates the character 26 in three-dimensional space.

[0020]The other start keys 9 required for a game and selection key 11 grade are also provided in

the stand 1 of the joystick 12. Operation in case the character 26 is displayed on three-dimensional space which has a XYZ axis on the screen of the display device 15 of drawing 4 is considered.

[0021]If the spherical shell 5 of the stand 1 is \*\*\*ed and the base 2 is head for the first time in rotated to the stand 1, the value of the X-axis volume 10 and the Y-axis volume 20 will be changed, and these output values will be sent to the display control circuit 90.

[0022]The image data of the solid character 26 is also inputted into the display control circuit 90 from the picture generation circuit 80, The value of the volumes 10 and 20 becomes position data of the character 26, and, as for the value change of the X-axis volume 10 and Y-axis Ruhm 20, the character 26 performs movement in an XY plane in three-dimensional space.

[0023]If the spherical shell 5 is \*\*\*ed, and the chief editor 3 is pushed or lengthened and is slid to the base 2 with this, the value of the Z-axis volume 30 will also be changed and, in addition to an XY plane, the character 26 will move also to Z shaft orientations in three-dimensional space.

[0024]Next, if the spherical shell 5 is \*\*\*ed, a finger is used and the sphere 6 is rotated via the ball bearing 7 within the spherical shell 5, The X-axis rotating volume 15, the Y-axis rotating volume 16, and the Z-axis rotating volume 17 also rotate according to the counteraction, the value of these rotating volumes 15, 16, and 17 also changes, and the character 26 rotates centering on X-axis Y-axis Z shaft orientations in three-dimensional space, respectively. The hand of cut, angle of rotation, and speed of the character 26 adjust the rotational speed of the sphere 6, can set it as direction of a request, and when required, they can also give rotation.

[0025]Therefore, in XYZ space, carrying out three-dimensional movement, the sphere 6 rotates focusing on the X-axis, a Y-axis, and Z shaft orientation, and comes to have the flexibility of 6-dimensional ones. According to the 6-dimensional joy stick of this invention, it adds to movement to an X axial direction, Y shaft orientations, and Z shaft orientations, Since change of direction of the character which sets the axis of rotation as each of an X axial direction, Y shaft orientations, and Z shaft orientations is attained, as compared with the conventional joy stick, the flexibility of a motion of a character increases substantially, and creation of the game which was varied more than former is attained.

---

[Translation done.]

**\* NOTICES \***

JPO and INPIT are not responsible for any damages caused by the use of this translation.

1.This document has been translated by computer. So the translation may not reflect the original precisely.

2.\*\*\* shows the word which can not be translated.

3.In the drawings, any words are not translated.

---

**DESCRIPTION OF DRAWINGS**

---

[Brief Description of the Drawings]

[Drawing 1]It is a general schematic block diagram of the joystick for the games of this embodiment of the invention 1.

[Drawing 2]It is a mimetic diagram of the mounting structure of the third sensor of the joystick for the games of this embodiment of the invention 1.

[Drawing 3]It is a mimetic diagram of the mounting structure of the first sensor of the joystick for the games of this embodiment of the invention 1, and the second sensor.

[Drawing 4]It is the whole game device block diagram containing the joystick for the games of this embodiment of the invention 1.

[Explanations of letters or numerals]

1 Stand

2 The base which is the first operating rod

3 The chief editor who is the second operating rod

5 The spherical shell which is an attaching part

6 Sphere

10 X-axis volume of the first sensor

12 Joystick

13 Indirect ball

15 X-axis rotating volume of the first volume

16 Y-axis rotating volume of the second volume

17 Z-axis rotating volume of the third volume

20 Y-axis volume of the second sensor

30 Z-axis volume of the third sensor

25 Display device

26 Character

80 Picture generation circuit

90 Picture display control circuit

---

[Translation done.]

(19) 日本国特許庁 (J P)

(12) 公開特許公報 (A)

(11) 特許出願公開番号

特開平10-207624

(43) 公開日 平成10年(1998) 8月7日

(51) Int.Cl.<sup>6</sup>

G 0 6 F 3/033  
A 6 3 F 9/22

識別記号

3 3 0

F I

G 0 6 F 3/033  
A 6 3 F 9/22

3 3 0 F

F  
C

審査請求 未請求 請求項の数1 OL (全4頁)

(21) 出願番号

特願平9-7834

(22) 出願日

平成9年(1997) 1月20日

(71) 出願人 000132840

株式会社タイトー

東京都千代田区平河町2丁目5番3号 タ  
イトービルディング

(72) 発明者 阿河 肇

東京都千代田区平河町二丁目5番3号 株  
式会社タイトー内

(74) 代理人 弁理士 八嶋 敬市

(54) 【発明の名称】 ゲーム用のジョイスティック

(57)

y	v	a	i	c	島				
y	z	Q	[	L	N	^	算		
~	~	A	、	~	算				
b	N	a	B						
y	z	W	C	X	e	b	N	蓋	
'	¥	fl	%	⊕				器	
%	a		b	h	~	A		器	
	~	-	⊕	a	fi	'	¥	器	
⊕	b	h	~			a	]	+	器
%	P	Z	T	[	y		Q		器
a	b	h	~		fl	%			器
~			a	]	+	"	φ		器
{	[	~	~	a	A	O	~		器
c	~	~	L	~	~	~	~		器
⊕	b	h	~			a	~		器
~	~			a	]	+	"	~	器
∅	B		~	R	+	~	~		器

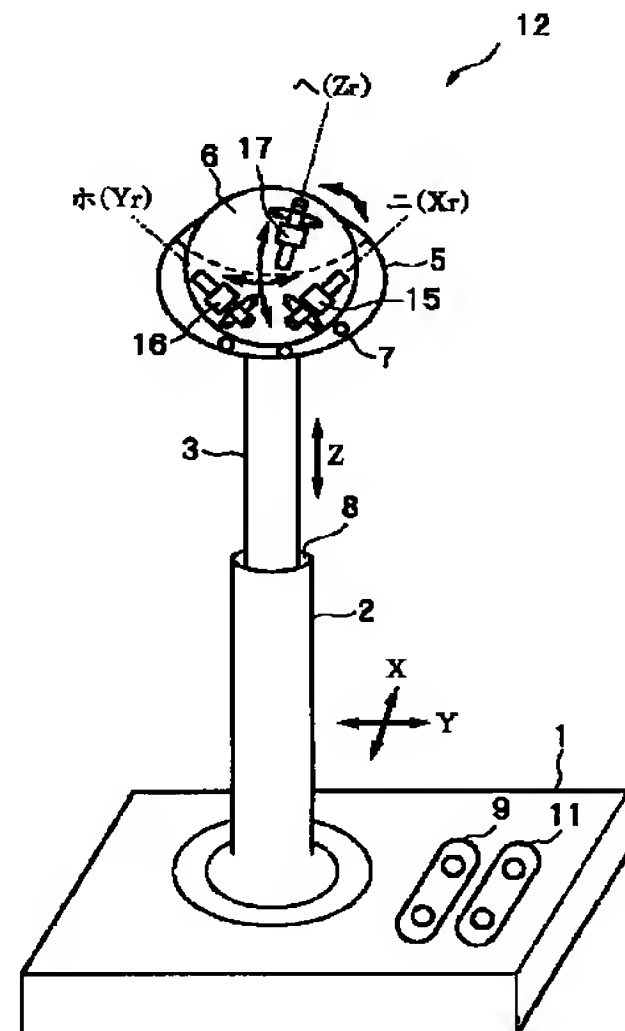

Y `      2      ž  
Y 2      P      Q      [      >      ¶      -      ¶      <      %





5  
 Y } ° " 〇  
 Y } P z - >  
 e b N S " 〇  
 Y } Q z - >  
 e b N O Z T [ 〇  
 Ø B  
 Y } R z - >  
 e b N 〇 Z T [ 〇  
 < " fi 〇  
 Y } S z - >  
 e b N Q [ 〇  
 Y z  
 P  
 Q 〇 〇  
 R æ 〇

T - 〇  
 U  
 P O 〇 Z T [ 〇  
 P Q W C X  
 P R  
 P T 〇 { [ 〇  
 P U æ { [ 〇  
 P V O { [ 〇  
 Q O æ Z T [ 〇  
 R O O Z T [ 〇  
 Q T ¥ f u  
 Q U L N  
 W O > 〇 H  
 X O ¥ f 〇

Y } 〇

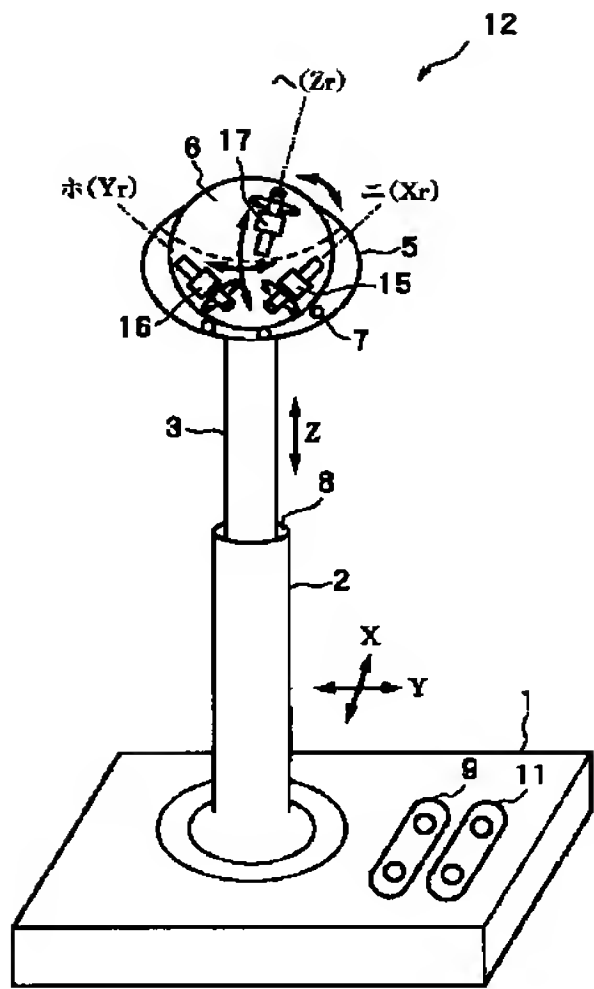

Y } 〇

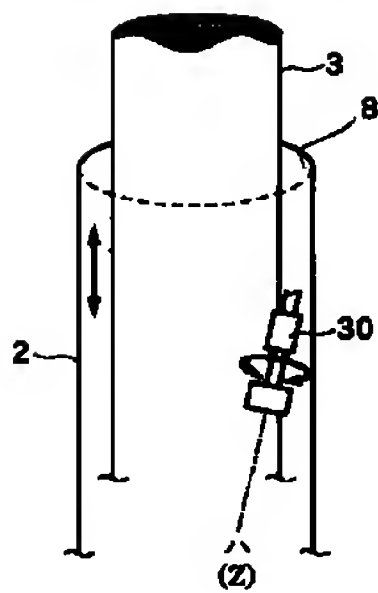

Y } 〇

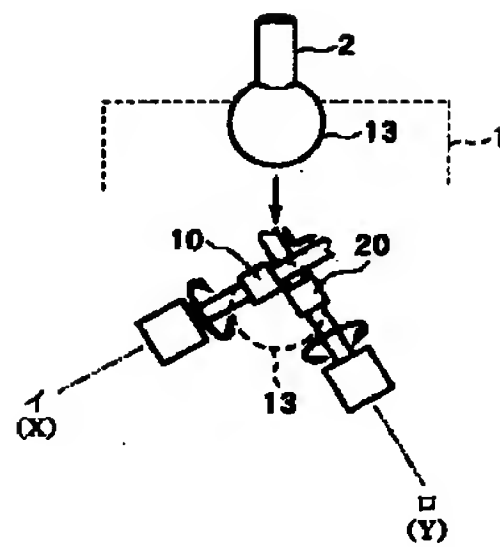

Y } 〇

